

Free-Expanding and Bounded Discharge in Xe Flashlamp

D.V. Rybka¹, M.I. Lomaev¹, E.H. Baksht¹, V.F. Tarasenko¹,
M. Krishnan², J. Thompson²

¹High Current Electronics Institute, SB RAS, 2/3, Akademicheskoy Ave., Tomsk 634055 Russia;

²Alameda Science Corporation, 94577 San Leandro, CA USA

Phone: 7-3822-492-392, Fax: 7-3822-492-410, E-mail: RDm@loi.hcei.tsc.ru

Abstract – Different excitation regimes of a discharge in a xenon flashlamp are studied. It is shown that in passing from the oscillating discharge current to the unidirectional current pulse, the UV power radiation increases, while the FWHM of the radiation pulses decreases. The maximal density of UV radiation power on plasma surface of a free-expanded discharge was $\sim 1.3 \text{ MW/cm}^2$, the maximal brightness of a discharge in the UV spectral range was $\sim 0.37 \text{ MW/(sr}\cdot\text{cm}^2)$. For a discharge with short risetime of a radiation pulse ($< 1 \mu\text{s}$), bounded by the walls of a bulb, the maximal power density on the internal surface of the bulb was $\sim 700 \text{ kW/cm}^2$, that corresponds to $\sim 380 \text{ kW/cm}^2$ on its external surface.

1. Introduction

Over more than the last two decades the attempts have been made to develop an efficient radiation source to control a high-voltage diamond switch. The control of this switch by an electron beam [1] and a UV laser [2] has been demonstrated. However, an electron accelerator and a laser are too complicated and expensive to be used in industrial switches. In this connection it is necessary to create a high-power and moderately priced UV radiation source to control the diamond switch [3]. This source should emit microsecond pulses predominantly in the UV region (the fundamental absorption band of a diamond crystal lies in the wavelength range $\lambda < 225 \text{ nm}$, while impurities absorb at $\lambda > 225 \text{ nm}$ [4]). Noble gas-discharge flashlamps are promising radiation sources for this spectral region [5]. These lamps are used, for example, for UV pumping organic dye lasers. Compared to discharges in other noble gases, a discharge in xenon has the largest gradient of the potential and the smallest voltage drop in near-electrode regions, so that it is most efficient for using in flashlamps [6].

The aim of this investigation is to find the Xe discharge regimes providing an increase in the power and power density of microsecond radiation pulses in the spectral range between 200 and 400 nm.

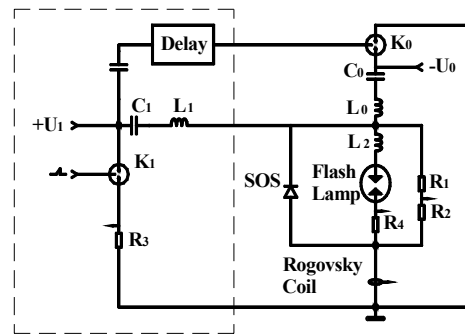

Fig. 1. Electrical circuit of the experimental setup

2. Experimental setup

The discharge in xenon was produced by using a pulsed generator, whose electric circuit is presented in Fig. 1. Such a generator was earlier employed for pumping different lasers and is described in detail in [7]. Three operating regimes of the generator were used in experiments. In regime 1, the generator operated with switched off SOS (semiconductor opening switch) diodes (a conventional electric circuit of the LC generator consisting of a storage capacitor C_0 , a switch K_0 , the inductance of the discharge circuit connections and a flashlamp placed in series). Regime 2 differed from regime 1 by the connection of SOS diodes in parallel with the flashlamp (up to 24 SOS diodes were connected). In regime 3, the discharge current of an additional capacitor C_1 was preliminary passed through the SOS diodes in the forward direction (the block of direct pumping of SOS diodes is outlined by the dashed line in Fig. 1) and then, after switching on the switch K_0 , in the backward direction, which resulted in the current breaking in SOS diodes and formation of a high-voltage pulse. This was accompanied by the breakdown of the discharge gap in the flashlamp and switching of the current flowing through SOS diodes to the discharge gap. The flashlamp was filled with xenon at a pressure of 50 – 1000 Torr. The interelectrode gap was varied from 2 to 23 mm. The cylindrical flashlamp tube with an internal diameter of 20 mm was made of quartz transmitting no less than 85 % of radiation in the spectral region from 200 to 400 nm. In experiments with a discharge

restricted by the flashlamp walls, a similar flashlamp tube of internal diameter 3 mm was used. The optical characteristics were recorded with an EPP2000C-25 spectrometer equipped with a CCD linear array (sensitive in the 200 — 850-nm spectral range) and a FEK-22SPU coaxial photocell (sensitive in the 200 – 650-nm range). The discharge glowing was photographed by a SensiCam CCD camera. Discharge current and voltage pulses on the flashlamp electrodes were detected by a current shunt R_4 , a Rogowsky coil, and an ohmic voltage divider R_1 , R_2 , whose output signals were fed into a Tektronix TDS-224 oscilloscope. The capacitances of capacitors used in experiments were $C_0 = 260 - 376$ nF, $C_1 = 34 - 110$ nF and their charging voltages were $U_0 = 0 - 30$ kV and $U_1 = 0 - 35$ kV. The SOS diodes with the reverse voltage up to 50 kV and breaking current up to 2 kA were used in the generator. The parameters of a freely expanding discharge and a discharge restricted by the flashlamp tube walls were compared by exciting the flashlamp using an LC generator with a storage capacitor of 165, 266, 376 or 1376 nF and the charging voltage up to 35 kV.

3. Experimental results and discussion

We studied different regimes of the energy input to the discharge, as well as regimes of the freely expanding discharge and the discharge restricted by the quartz tube walls. The interelectrode gap and Xe pressure in the flashlamp were preliminary optimized. Figure 2 shows the dependences of the peak radiant intensity and linear peak radiant intensity on the interelectrode gap. In this case, the Xe pressure was 400–600 Torr (depending on the interelectrode gap) and was selected

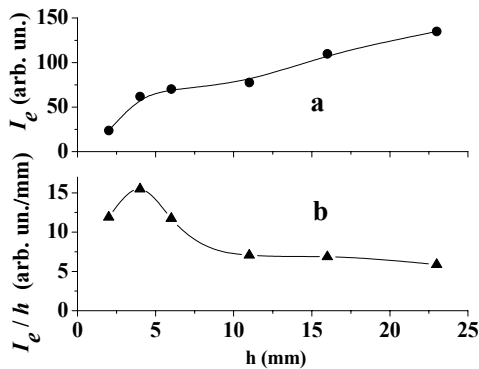

Fig. 2. Dependences of the radiant intensity I_{emax} (a) and linear peakradiant intensity I_{emax}/h (b) of a Xe flashlamp in the wavelength range 200 – 850 nm on the interelectrode gap h in regime 1 for $C_0=233$ nF and $U_0=15$ kV

to obtain the maximum UV radiation intensity for a given interelectrode gap. Our experiments showed that, as the interelectrode gap decreased from 4 to 2 mm, the relative intensity of UV radiation in the emission spectrum increased, but the peak radiant intensity

drastically decreased. When the interelectrode gap exceeded 4 mm, the intensity of the emission spectrum below 250 nm, where a diamond crystal absorbs light most efficiently, decreased, i.e., the spectral efficiency in this wavelength region decreases (Fig. 3).

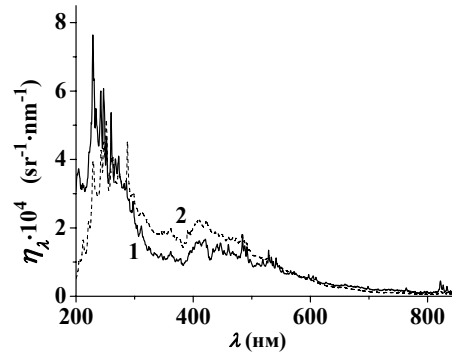

Fig. 3. Spectral efficiency η_λ of the Xe flashmap. The interelectrode gap $h=4$ (1) and 23 mm (2)

The optimal interelectrode gap in all the successive experiments was 4 mm. The operating Xe pressure in the flashlamp was selected based on the following considerations: a pressure is changed from 50 to 100–300 Torr, the peak radiation power of the discharge increases, while at $p > 300$ Torr, this increase almost ceases, although the energy input to the discharge and the radiation energy continue to increase. At the same time, at pressures of the order of atmospheric and greater energy inputs, a quartz flashlamp tube was destructed. Therefore, we selected the operating pressure $p = 550$ Torr, which allowed us to work at rather high radiation energies and to obtain high peak powers. By studying the regimes of energy input to the discharge, we recorded the discharge current, voltage across electrodes, power and emission spectrum of the discharge, and photographed the discharge glowing at different instants by a CCD camera. Figure 4 shows the current oscillograms and time dependences of the radiant intensity in the Xe discharge at different voltages for regimes 1 and 3 of the generator operation. Curves (1) and (2) in Fig. 4 correspond to the oscillating current regime in the discharge, while curves (3) and (4) correspond to the unidirectional current pulse regime. One can see that in the case of a unidirectional discharge current pulse, the radiation power and the radiant intensity of the flashlamp, proportional to the radiation power, increase, whereas the FWHM of the radiation pulse decreases. Even a greater increase in the radiation power was achieved in regime 2 of the pulsed generator because in this regime there are no losses in SOS diodes at the direct pumping and current breaking stages.

The increase in the peak radiation power of the flashlamp in regimes 2 and 3 compared to regime 1 can be explained by the absence of oscillations of the

electric power released in the discharge (excitation power). Upon excitation of the flashlamp by the generator in regime 1 (*LC* generator), the discharge current oscillates, which results in inevitable pulsations of the excitation power. As this power is decreased to zero, the discharge plasma is efficiently cooled. This

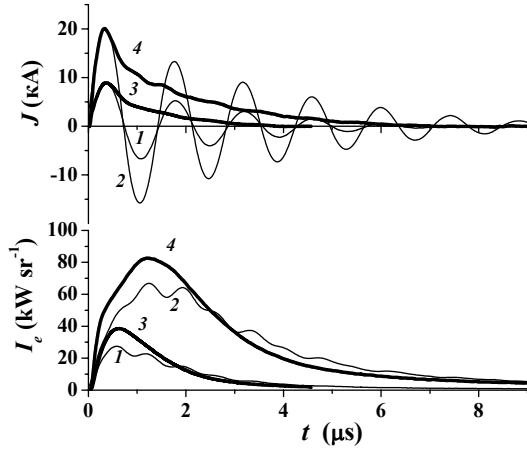

Fig. 4. Discharge current J and the Xe flashmap in the wavelength range 200–850 nm in regimes 1 [(1), (2)] and 3 [(3), (4)] for $C_1=34$ nF, $U_1=15$ kV [(3), (4)], $U_0=9,5$ [(1), (3)] and 24 kV [(2), (4)], $C_0=260$ nF, and $L_2=170$ nH

in turn causes pulsations of the radiation power (curves (1) and (2) in Fig. 4). As the voltage U_0 increases, the redistribution of the power in the peaks of the excitation pulse occurs (the peak corresponding to the second half-period of the current increases). In regimes 2 and 3, the current flows through the flashlamp in one direction and, unlike regime 1, the power supplied to the discharge almost does not exhibit pulsations. This leads to an increase in the peak power and a decrease in the FWHM of the radiation pulse compared to those in regime 1. Regime 2 differs from regime 3 by the absence of a short high-voltage pulse, which is formed upon current breaking in SOS diodes and ignites a discharge in the flashlamp at high pressures and a large interelectrode gap. Note that the charging voltage of the capacitor C_0 was sufficient for a stable breakdown of xenon in the flashlamp in regime 2. In regime 3, the additional possibility appears to change the current J_{sw} switched from SOS diodes to the flashlamp (Fig. 5) by varying the breaking current. An increase in the switched current provides an increase in the power released in the discharge at the initial stage.

Figure 5 shows the typical oscillogram of the current flowing through the flashlamp in regime 3. The attempts to reduce the ratio J_{max}/J_{sw} resulted in this case in a decrease in the peak radiant intensity of the flashlamp compared to that in regime 2. This is clearly demonstrated in Fig. 6, where the experimental de-

pendences of the peak radiant intensity I_{emax} of the flashlamp in the 200–850 nm range on the energy W_0 stored in the generator are presented. The points corresponding to the generator operation in regime 2 are well fitted by the straight line $I_{emax} \sim W_0^{0.5} = (C_0 U_0^2/2)^{0.5}$ (dashed straight line in Fig. 6). A similar

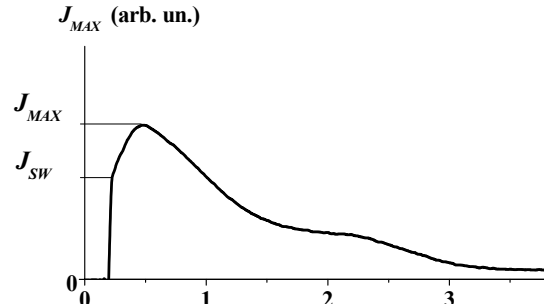

Fig. 5. Oscillogram of the current J through the flashmap in generator regime 3

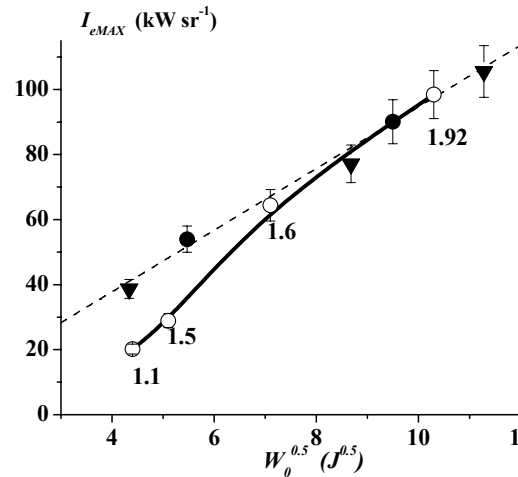

Fig. 6. Dependence of the peak radiant intensity I_{eMAX} of the flashmap in the wavelength range 200–850 nm on $W_0^{0.5}$ in regime 3 for $C_0=266$ nF, $C_1=110$ nA (\circ) and in regime 2 for $C_0=266$ nF (\bullet) and 376 nA (\blacktriangle)

empirical dependence is valid for the luminous intensity [8]. The ratio J_{max}/J_{sw} was reduced from 1.92 to 1.1 by decreasing the voltage U_0 from 30 kV to zero (the voltage U_1 remained equal to 35 kV). As U_0 was increased, the ratio J_{max}/J_{sw} increased, the relative energy losses in SOS diodes decreased (with respect to the energy stored in the generator) and the peak radiation powers of the flashlamp in regimes 3 and 2 became equal for the same stored energy. For $U_0 = 30$ kV (regime 2), the radiation energy in the 200–400 nm range achieved ~ 2 J. Note that the peak radiation power in regimes 2 and 3 increases compared to that in regime 1 at approximately the same energies of the radiation pulse.

We also studied the flashlamp operation in the regimes of a freely expanding discharge and a discharge restricted by the flashlamp tube walls by exciting the lamp with a conventional *LC* generator. In the case of a freely expanding discharge, the maximum power density in the wavelength range 200–400 nm obtained in the experiment was, according to our estimates, ~ 110 and ~ 80 kW cm⁻² on the internal and external surfaces of the flashlamp tube, respectively, while the radiant intensity was ~ 110 kWsr⁻¹ for the stored energy of 615 J. The diameter of the current channel at the instant of the maximum brightness was ~ 1.3 mm. The estimates of the radiation power density and brightness become valid within 200 ns after the discharge ignition (the Xe discharge photographs obtained by a CCD camera showed that a multichannel breakdown of the discharge gap almost always occurred; then, individual channels expanded and merged into one already after ~ 200 ns). The maximum UV radiation power density on the discharge plasma surface was ~ 1.3 MW cm⁻² and the maximum UV brightness of the discharge was ~ 0.37 MW sr⁻¹ cm⁻².

By using a discharge with a steep leading edge of the radiation pulse restricted by the flashlamp walls [9], we can obtain higher power densities on the inner (and outer) surfaces of the lamp tube. The power density was estimated from the ratio P_1/S_2 , where P_1 is the discharge power density at the instant of the maximum of the power density and S_2 is the surface area of a cylinder of height equal to that of a plasma column of the discharge at the same instant and diameter equal to the outer diameter of the flashlamp tube. The duration of the radiation pulse front was shorter than 1 μ s. The maximum UV power density on the inner and outer surfaces of the flashlamp was ~ 700 and ~ 380 kW cm⁻², respectively.

It is obvious that to produce a high conduction in a diamond switch, it is necessary to provide the maximum UV power density on the switch. In the freely expanding discharge regime, the output power increases with increasing stored energy, while the power density on the lamp surfaces decreases because the minimal possible diameter of the flashlamp tube also increases with increasing energy. Therefore, to provide the efficient use of radiation from the flashlamp operating in this regime, it is necessary to employ an optical system focusing radiation on the switch and to obtain the required power density by increasing the energy stored in the excitation generator. A discharge with a steep leading edge of the radiation pulse can be obtained by placing the switch close to the quartz flashlamp tube.

4. Conclusions

We have studied the spectral, energy, and time characteristics of a pulsed Xe discharge by using three regimes of energy supply to the discharge and compared these regimes. It is shown that in passing from the oscillating discharge to the unidirectional current pulse regime, the output power of the radiation source increases, while the FWHM of the radiation pulse decreases.

We have compared the regimes of a freely expanding discharge and a discharge restricted by the flashlamp walls. It is shown that to produce a high conduction in the diamond switch in the freely expanding discharge regime, it is necessary to use an optical focusing system. The maximum UV power density on the plasma surface in a freely expanding discharge was ~ 1.3 MW cm⁻² and the maximum UV brightness of the discharge was ~ 0.37 MW sr⁻¹ cm⁻². For a discharge with a steep leading edge of the radiation pulse (shorter than 1 μ s) restricted with the flashlamp walls, the maximum UV power density on the inner and outer surfaces of the flashlamp was ~ 700 and ~ 380 kW cm⁻², respectively.

Acknowledgements

This work was supported by the ISTC (Grant No. 2706) and RFBR (Grant No. 05–08–33621–a).

References

- [1] M. Krishnan, X. Xu, J. Schein, N. Qi, R. Prasad, S. Gensler, *Proc. XII IEEE Pulsed Power Conf.*, Monterey, CA, USA, 1999, pp. 1222–1225.
- [2] R. Prasad, J. Schein, S. Gensler, and M. Krishnan, *in Proc. XII IEEE Pulsed Power Conf.*, Monterey, CA, USA, 1999, pp. 142–145.
- [3] D.V. Rybka, E.K. Baksht, M.I. Lomaev, V.F. Tarasenko, M. Krishnan, and J. Thompson, *Technical Physics*, **50**, 270 (2005).
- [4] G.B. Bokii, G.N. Bezrukov, Yu.A. Klyuev, A.M. Naletov, V.I. Nepsha, *Natural and Synthetic Diamonds*, M.: Nauka, 1986.
- [5] *Encyclopedia of Low-temperature Plasma. Introductory Vol. IV*, ed. by V.E. Fortov, M.: Nauka, 2000.
- [6] G.N. Rokhlin, *Discharge Current Light Sources*, M.: Energoatomizdat, 1991.
- [7] E.K. Baksht, A.N. Panchenko, V.F. Tarasenko, *Quantum Electronics*, **30**, 505 (2000).
- [8] *Pulsed Light Sources*, ed. by I.S. Marshak, M.: Energiya, 1978.
- [9] Yu.G. Basov, *Pump Sources for Microsecond Lasers*, M.: Energoatomizdat, 1990.